

RADIATOR TRAPS

Low Pressure (900 Series)

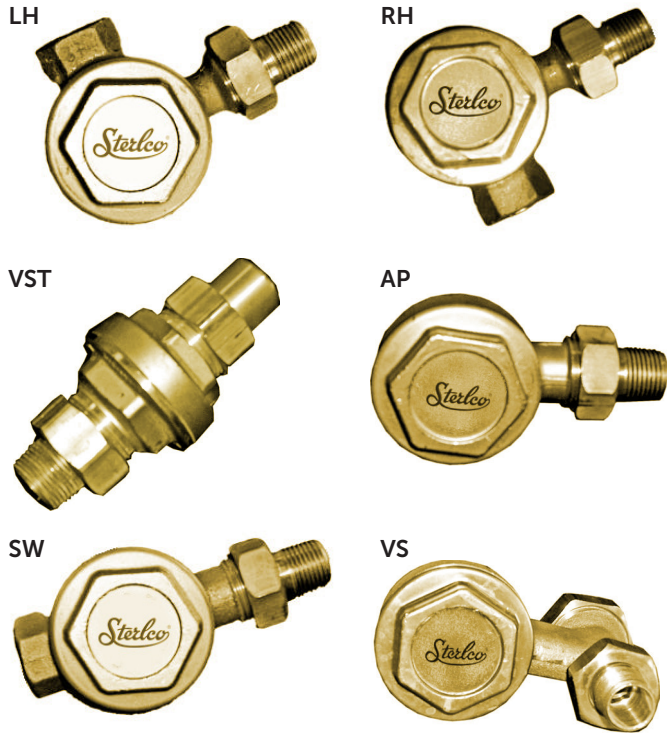

Technical Specifications

The Sterlco® Low Pressure Radiator Trap is applicable to all types of low pressure or sub-atmospheric steam heating systems and operates efficiently with pressures from 25" vacuum to 25 PSI. Its purpose is to efficiently drain water and vent air from a radiator or heating element and to prevent steam from entering return piping. The trap is manufactured in three sizes for handling capacities of 30 to 175 lbs./hr. and in six patterns which permit easy installation with a minimum of pipe fittings.

Features

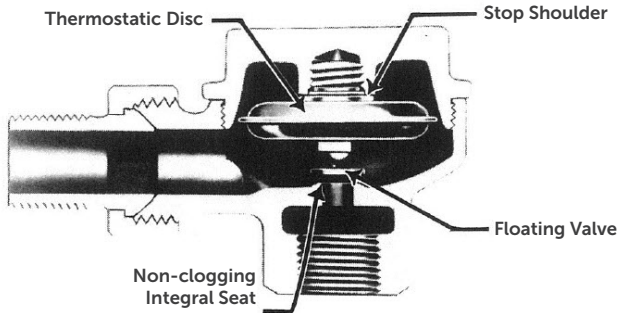

- **Simple, rugged construction** - The trap consists of a cast brass body and cover with a fluid filled thermostatic disc. All working parts are made of non-corrosive metals especially adapted for dependable service.
- **Sensitive thermostatic action** - Sealing the thermostatic disc under high vacuum assures sensitive and positive response to temperature and pressure over trap's entire operating range. Disc corrugations are shaped to reduce hinge action at the rim of the disc and distribute disc motion.
- **Minimum wear on working parts** - Due to the unique design of the floating valve and rounded seat, corrosive elements and dirt normally found in heating system piping will not seriously affect the operation of the trap. The valve's square and tight seating is assured by the ball swivel joint which holds the valve and disc together. The swivel joint prevents localized stresses on the disc and also prolongs the life of the valve and seat by preventing wear in any one spot.

- **Freedom from clogging** - Slightly raised and rounded seat permits intimate contact with valve and reduces area for accumulation of incrustants. Large valve opening permits easy passage of water and dirt, thereby ridding trap of foreign matter which could cause clogging.
- **Thorough tests** - In addition to tests made of the completed trap, each thermostatic disc is checked by an automatic leak detector. Each thermostatic disc must pass a test which will detect a leak so small that in a year's time less than 1/100 of an ounce of thermostatic fluid could escape. All traps are 100% test operated before leaving the factory.
- **Minimum maintenance** - Permanent adjustment for correct operation is built into each Sterlco® trap. Stop shoulder in trap cover permits disc assembly to be screwed in a predetermined distance. This distance provides the proper amount of clearance between the valve and seat for free drainage of condensate and also enables the valve to seat squarely and tightly when in a closed position. If, under unusual conditions, it is necessary to replace a thermostatic element, even then no adjustment is necessary.

Available Repair Kit

Repair Cartridge Unit for 900 Series Traps with Integral Seat

The Sterlco® cartridge unit was developed to allow repair of integral seat traps without the need of removing the trap from the system piping. The cartridge consists of a new seat, disc, valve and cap installed quickly by removing the old cap and disc and screwing in the cartridge. The old trap is thus renewed with the same full flow capacity as the original.

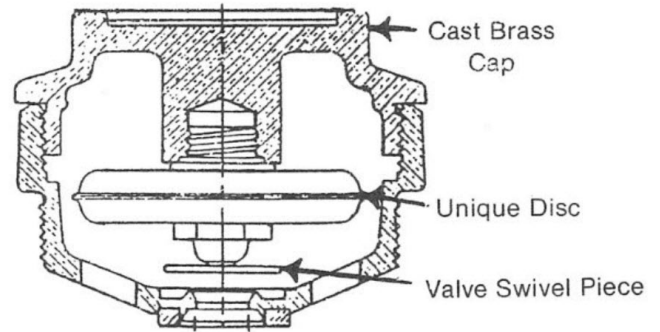

Capacities, Dimensions & Weights

Model	Patt.	Tap.	Pressure Differential (PSI) lbs. condensate per hour			Dimensions (inches)					Ship. Wt. lbs.
			1/2 lb.	1 lb.	1.5 lbs.	A	B	C	D	E	
950-A	AP	1/2	30	40	50	3-1/8	1-1/8	-	2-7/16	-	1-1/4
970-S	SW	1/2	30	40	50	3-1/8	-	1-3/4	2-7/16	1/2	1-3/8
970-R	RH	1/2	30	40	50	3-1/8	-	1-3/4	2-7/16	1/2	1-3/8
970-L	LH	1/2	30	40	50	3-1/8	-	1-3/4	2-7/16	1/2	1-3/8
980-VS	VS	1/2	30	40	50	See Figure 4					1-1/4
953-A	AP	3/4	60	80	100	3-3/16	1-1/8	-	3-1/16	-	1-7/8
973-S	SW	3/4	60	80	100	3-3/16	-	1-3/4	3-1/16	1/2	1-7/8
983-VST	VST	3/4	30	40	50	See Figure 5					1-1/4
915-A	AP	1	100	140	175	3-7/16	1-1/8	-	3-1/16	-	2

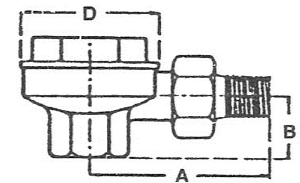

Fig. 1 - Angle Pattern (AP)

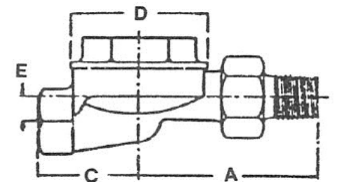

Fig. 2 - Straight-Way Pattern (SW)

Meeting the standards of

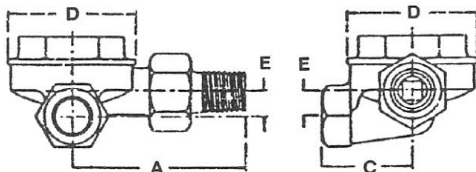

Fig. 3 - Right Hand Pattern (RH)
Left Hand (LH) Pattern is Similar

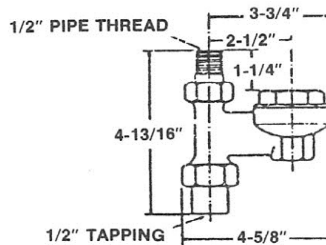

Fig. 4 - Vertical Straight-Way Pattern (VS)

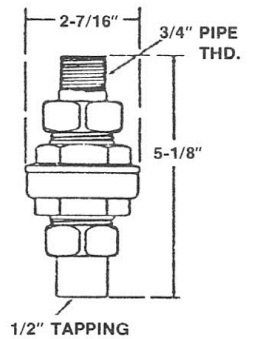

Fig. 5 - Vertical Straight-Thru Pattern (VST)

Typical Specification

The contractor shall furnish and install as specified in the plans and in accordance with the manufacturer's instructions _____ (size: 1/2", 3/4" or 1") _____ (configurations: AP, SW, RH, LH, VST or VS) Sterlco® Model 900 Series _____ Low Pressure Radiator Trap, which has a capacity rating of _____ lbs./hr. @ _____ PSI differential. The trap body and cap shall be made of cast brass. All other parts shall be made of non-corrosive materials. The thermal expansion disc shall be plasma-arc welded construction, of non-corrosive materials, and have annual corrugations to reduce fatigue on welded joints. It is fluid-filled and sealed under vacuum, factory calibrated for quick accurate field replacement, and securely mounted in the cap. The trap shall have a flat valve piece attached to the disc with a ball swivel joint to assure positive shut-off. The disc design shall be tested to endure 10,000,000 cycles with no hermetic failure. The trap body shall have a large diameter seat opening for abundantly high resistance to wear. The trap shall operate efficiently at pressures from 25" vacuum to 25 PSI.